

Load and PV Generation Forecast Based Cost Optimization for Nanogrids with PV and Battery

M. Ugur Gudelek

Department of Computer Engineering
TOBB Economy and Technology University
Ankara, Turkey
mgudelek@etu.edu.tr

Cem R. Cirak

Department of Electrical
and Electronics Engineering
Middle East Technical University
Ankara, Turkey
turkmavisi@iee.org

Efe Arin

Department of Electrical
and Electronics Engineering
Gazi University
Ankara, Turkey
efearin@gazi.edu.tr

Mustafa Erdem Sezgin

Department of Electrical
and Electronics Engineering
Middle East Technical University
Ankara, Turkey
erdems@metu.edu.tr

A. Murat Ozbayoglu

Department of Computer Engineering
TOBB Economy and Technology University
Ankara, Turkey
mozbayoglu@etu.edu.tr

Murat Gol

Department of Electrical
and Electronics Engineering
Middle East Technical University
Ankara, Turkey
mgol@metu.edu.tr

Abstract—Power system resiliency and robustness became major concerns of the system operators and researchers after the introduction of the smart grid concept. The improvements in the battery storage systems (BSS) and the photovoltaic (PV) systems encourage power systems operators to enable the use of those systems in resiliency and robustness studies. Utilization of those systems not only contributes to the robustness of the power systems but also decrease the operational costs. There are several methods in literature to operate the grid systems with partitions of PV and BSS in the most economical way. Although these methods are straightforward and work fine, they can not guarantee the most economical result on a daily basis. In this paper, deep learning based PV generation and load forecasts are used to improve the results of optimization in terms of economic aspects in nano-grid applications. In the considered system, there are loads, PV generation units, BSS and grid connection. Bi-directional power flow is permitted between the main grid and the nano-grid system. The forecasting methodologies and used optimization algorithms will be explained in this paper.

Keywords—smart grids, demand-side management, forecasting, mathematical programming, recurrent neural networks

I. INTRODUCTION

Transmission operators were used to utilize hydro and thermal power plants for electric power generation. However, nowadays with the help of social awareness about the environment, the penetration of wind and solar energy has accelerated [1]. Moreover, the use of home type battery storage systems has already started, thanks to the enhancements in the battery technologies. Although these developments are environment friendly, they also bring operational challenges to the system operators, because of decreased system inertia and uncertain generation characteristics. As a solution of these challenges, the smart grid concept arises [2].

In general, smart grid can be used for large-scale systems. In much smaller systems, such as a building with dispatchable

power units and distributed generation units, nanogrid concept can be used. Demand side management is one of the most important topics in the smart grid and nanogrid concepts. To operate the system properly, power consumption is aimed to be made constant throughout the day by the use of time-of-use (ToU) tariff, which is one of the most a popular demand-side management approaches among the distribution companies. In this work, a demand side management problem for a low voltage system customer with photovoltaic (PV) and battery storage systems is considered, as a nanogrid application.

Nanogrid applications help decreasing the CO₂ emissions, but most importantly they are economically advantageous. By using the renewable sources, especially PV systems at rooftops, and the battery storage systems (BSS), the operating cost of the nanogrid can be decreased. In [3] and [4] the economic optimization of the nanogrid is done for the time instant at the calculation. In addition, in [3], it is given that, the use of renewable and load forecasts may increase the performance of economic optimization of the nanogrid system.

In this paper, it is proposed to use a forecast aided controller for PV and battery penetrated nanogrid applications. Use of the proposed method instead of the pre-defined instant operation scenarios can decrease the operation costs of the nanogrids. The proposed control strategy utilizes the forecasts of the PV generation and load demand, which are based on the long-short-term-memory (LSTM) method. The optimization problem, which constitutes the control strategy, is formed as a mixed integer linear programming (MILP) problem.

Organization of the paper is given as follows. In Section II, the literature review about the topic will be given. In Section III, the methodology used in optimization and forecast will be explained. In Section IV, the numerical results will be shown. Finally, paper will be concluded with Section V.

II. RELATED WORK

In recent years, thanks to improvements in computer science and ease at the side of creating and reaching big data, instead of static strategies, trending topic artificial intelligence starts to get a role in power optimization approaches. In this area, mainly artificial neural network (ANN) along with support vector machine (SVM) approaches are used in recent years.

At the PV forecast side, as an example, in [5] short-term PV generation is forecasted using support vector regression (SVR) model with a rational root mean square error of 15.23%. With the same approach, [6] use also SVR for hour-ahead PV forecast for 6 kW capacity solar PV with an error of 2.6%. At the load forecasting side, [7] proposed an ANN-based method with an accuracy of 99.5%. SVM also used in the load forecasting side. For example, [8] proposed a parameter optimization method for SVM on their paper. Certainly, none of the mentioned works could be compared with this paper to see how well those methods work in forecasting since used datasets and cases are different. But they may give an approach in PV and load forecasting about what kind of learning methods are commonly used and approximately how their performances are.

Optimization in the nanogrids can be complicated as they become more and more complex. Several methodologies and techniques are used for the optimization of nanogrid structures. Mainly, the problem definition of the optimization function should be clearly defined. For example, in [9] the main purpose of the long-term optimization process is expressed as the investigation of the effect of battery system's lifetime to the regulation market. In [10], the authors try to optimize the battery lifetime by the use of adaptive dynamic programming.

In the optimization process, chosen optimization technique plays the most important role. Depending on the system structure different techniques, such as quadratic programming, linear programming, etc., can be used. For example, while in [11] quadratic programming is used for the minimization problem, in [12] particle swarm optimization technique is used. However, in these papers, optimal battery operation is decided not to reduce the long-term cost but to reduce the instantaneous cost to a minimum.

For different cost functions, different optimization techniques are used in the literature. However, the addition of the PV generation and load demand forecasts are not given. In this work, an optimization methodology will be presented which is enhanced by the use of PV and load forecasts.

III. METHODOLOGY

In this section, the hypothetical nanogrid system will be presented generically, the problem will be defined and main flow for the solution approach will be explained in Section III-A. Later on, forecasting details, chosen parameters and mathematical optimization model for such a nanogrid system will be explained under Section III-B and Section III-C, respectively.

A. Problem Definition

In designed nanogrid universe, such a hypothetical nanogrid system is chosen as seen in Fig. 1 that has a PV generation and a battery storage. In this system, pricing of energy from the grid has a time dependence (ToU tariff), where also selling energy back to the grid is allowed with a selling price multiplier m over buying price. PV and battery storage systems form the DC side of the nanogrid with a switch S_1 between them. With this representation, DC converters of individual components are not considered for simplicity. In the same way, grid and load with a switch S_2 between them form the AC side of nanogrid. An inverter with an efficiency η is located between AC and DC sides. Power flows through the grid, the PV, the battery and the load are called as P_G, P_{PV}, P_B, P_L respectively. Moreover, inverter and battery line have power limitations with the same value which will be indicated as I_{max} and B_{max} throughout the paper. Since the load demand and the PV generation can never be negative, they are modeled as unidirectional power flows. However, depending on the result of the optimization algorithm, power flows of the battery and the grid can be either positive or negative. Therefore, in these flows sign directions are considered as seen in Fig. 1. Additionally, E indicates stored energy in the battery while E_{max} indicates storage capacity. This paper deals with the challenge of minimization of the cost via power flow planning utilizing the load and the PV generation forecasts based on LSTM.

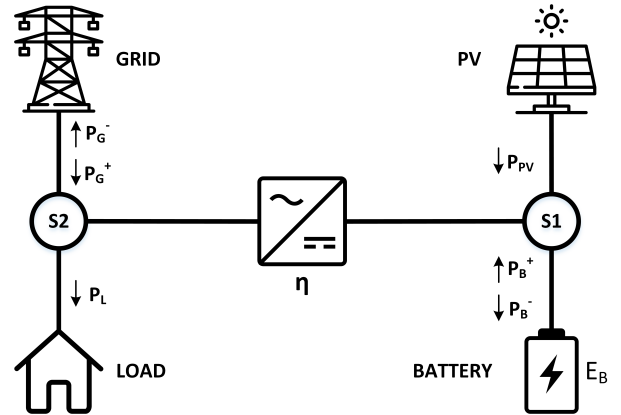

Fig. 1: Nanogrid structure

Structured solution approach has an algorithm flow diagram as shown in Fig. 2. First of all, bad data in PV generation and load power datasets are eliminated, in data cleaning step. Then, those cleaned datasets are divided into two parts as train and test. LSTM forecast models for both PV and load are set up and trained with train data. The created models are used to create forecasts. Then, forecasting performances are measured in comparison with both ENTSOE's forecasts and actual test values to show how well LSTM model fits. Afterward, those LSTM forecasts are fed into two optimization models, called as multi-time and single-time strategies and both use MILP approach. These two models find the most economic power

flows on the nanogrid system with given forecast values. Then the strategies passed to the mismatch handler with real case values of PV and load. This part calculates the cost by taking into account how the nanogrid acts when predicted values do not match with the actual ones. Output costs are compared in MILP strategy performance measure. Additionally, to obtain the impact of LSTM on overall performance, actual test data is fed into MILP model and the optimal cost is calculated. Then, this cost is compared to LSTM forecasts based strategies in terms of economical saving rates and saving optimality rates (ratios of realized saving to optimal saving) in overall optimization performance measure part.

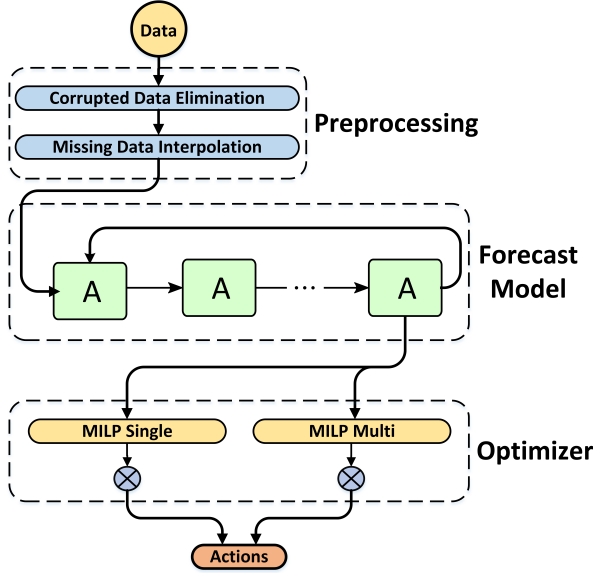

Fig. 2: Algorithm flow diagram

B. Forecast

In this part, not only the effect of optimization, but also the effect of a good forecast is examined. Therefore, this problem needs a forecast model to predict values of load and PV generation. In the following subsections, first, general information about dataset in Section III-B1, then, how LSTM is applied to the problem in Section III-B2 is going to be explained.

1) *Dataset*: In this problem, dataset retrieved from European Network of Transmission System Operators for Electricity (ENTSO-E) is used. The dataset has the data of one of the four electric company operates in Germany namely Amprion GmbH. It covers the load and PV generation of North Rhine-Westphalia, Rhineland-Palatinate and Saarland states. Although load data is available from 01.01.2010 to 31.12.2017, PV generation data is only available from 01.04.2011 to 31.12.2017. It consists of 4 quarters for each hour which results in 96 quarters for each day.

Retrieved data represents the whole country however in this paper, the forecast and optimization are planned to conduct for a household. In Germany, each household generates 2600 kWh

PV and consumes 3500 kWh in average. Therefore, values in the dataset are multiplied with different constants to obtain these average generation and consumption values.

As in datasets, there are missing and incorrect data, and therefore some cleaning process is necessary. For the load dataset, first, negative values is considered as incorrect data and set to 0 to be able to process later. Second, if the data of entire day is missing, most correlated data should be copied back to the missing day. As the data from one week later is most correlated in terms of seasonality, this particular day is used to handle missing days. Third and last, since all other missing data seems as small sensor defect or faulty operation, they are interpolated linearly. For the PV generation data, all steps are processed in the same way except the missing day. Missing days have used the data of consecutive day because of the high probability of having same weather condition.

For this particular problem, along with load and PV generation itself, 5 periodic signals are created to simulate hour, day, week, month and year in order to combine seasonality with the data.

2) *LSTM Model*: Recurrent Neural Networks (RNN) are used in many different areas. They use both the input and their previously computed data to predict next state. This natural design makes them a powerful tool for time series forecasts such as weather, finance and electrical demand forecast. As in many neural network architectures, RNNs are also using backpropagation, more specifically backpropagation-through-time, to update their weights to predict more accurately. However, they have one major drawback: vanishing gradient. Constructing a long chain of RNNs causes the vanishing of the gradient; therefore, the gradient cannot backpropagate to update earlier weights. To solve this drawback, a special kind of RNN is invented: Long Short-Term Memory (LSTM).

LSTM consists of 3 gates and 2 state vectors given in (1) which are *forget* (f_t), *input* (i_t), *output* (o_t) gates, *cell* (c_t) and *hidden* (h_t) state vectors respectively. Besides, x_t is the hidden state of the previous layer or i_t for the first layer at time t as σ is the sigmoid function and W s are the weights of the networks. *Forget gate* controls what to forget, *input gate* decides which values to store in *cell state vector*, *output gate* controls which parts of cell state vector need to output through *hidden state vector*. Therefore, these gates specialize in a particular task. It maintains easier learning process than a huge feed forward neural network.

$$\begin{aligned}
 i_t &= \sigma(W_{ii}x_t + b_{ii} + W_{hi}h_{t-1} + b_{hi}) \\
 f_t &= \sigma(W_{if}x_t + b_{if} + W_{hf}h_{t-1} + b_{hf}) \\
 g_t &= \tanh(W_{ig}x_t + b_{ig} + W_{hg}h_{t-1} + b_{hg}) \\
 o_t &= \sigma(W_{io}x_t + b_{io} + W_{ho}h_{t-1} + b_{ho}) \\
 c_t &= f_t * c_{t-1} + i_t * g_t \\
 h_t &= o_t * \tanh(c_t)
 \end{aligned} \tag{1}$$

For this problem, one LSTM architecture is constructed for both load and PV generation forecasts. Nevertheless, these forecasting problems are considered as separate problems and therefore two models are trained with this single architecture.

In this architecture, 96 LSTM cells are connected in consecutive order. Each cell is responsible to process the mix of one-quarter data and the output of the previous cell. After processing, they feed the output to the successive LSTM cell. When 96 cells are finished, data corresponding to the next quarter is predicted. The process window slides from time t to $t+1$ in order to predict other quarters. In other words, each new quarter is predicted using the entire data of previous day.

C. Optimization

The choice of the optimization algorithm plays an important role in the solution of economical operation of nanogrid. The original structure of this optimization problem is nonlinear. Nonlinearity in mathematical optimization problems significantly increases the computational complexity of the solution in comparison to linear problems. Thus, in the considered system, the aging of the battery is excluded from the problem definition due to its nonlinear nature. However, the optimization problem is still not linear but piecewise linear, because both cost function and the reciprocal inverter efficiency are piecewise linear. Thankfully, this kind of problems can be linearized by using just additional linear constraints and binary decision variables. By this means, for the optimization of the economic operation of the nanogrid, a MILP methodology is utilized. In the following parts, first, the detailed structure of mathematical MILP model in Section III-C1, then, working principles of applied optimization strategies in Section III-C2 and finally mismatch handler in Section III-C3 will be explained.

1) *MILP Model*: Used parameters for the designed nanogrid are given in Table I. \mathbf{P}_{L_n} , \mathbf{P}_{PV_n} and \mathbf{p}_n are the sets of parameters for time slot n (for $n=1,2,\dots,N$) of duration \mathbf{T} . Besides, \mathbf{p}_n is used for both Turkey and Germany ToU tariff prices as in Table II.

Decision variables called as \mathbf{P}_{G_n} , \mathbf{P}_{B_n} and \mathbf{E}_n where $n=1,2,\dots,N$ show the power flows through the grid and the battery, and the stored energy in the battery respectively. However, unsigned (unrestricted in sign) variables P_{G_n} and P_{B_n} cause unsigned constraints, and more importantly, unsigned P_{G_n} leads to piecewise linearity in the objective (cost) function due to different energy prices while buying and selling energy. In this case, MILP is not applicable for the problem unless it is linearized by representing P_{G_n} as difference of two nonnegative decision variables in the form of $P_{G_n}^+ - P_{G_n}^-$. To solve this issue, a binary variable and two extra constraints are added to the model. Linearity of the problem is preserved with usage of this kind of transformation. Since the effect of efficiency of the inverter depends on the direction of inverter power flow which is denoted by pseudo decision variable σ_n , a similar approach to aforementioned transformation is used to check whether the power flow is from the DC side to the AC side or vice versa.

The objective function and constraints are provided in (2) and (3)-(8) respectively, and the MILP model is designed as follows. The objective function represents the total net cost which equals to the cumulative sum of spendings due to

TABLE I: Parameters

| Parameter | Definiton | Value |
|------------|--|-------|
| N | Number of time slots in optimization process | 96 |
| m | Price multiplier | 0.9 |
| η | Inverter efficiency | 0.9 |
| T | Duration of time slot (h) | 0.25 |
| E_{max} | Battery energy storage capacity (kWh) | 6 |
| B_{max} | Battery line power capacity (kW) | 3 |
| I_{max} | Inverter power capacity (kW) | 3 |
| p_n | Energy price in slot n (price/kWh) | |
| P_{L_n} | Load power in slot n (kW) | |
| P_{PV_n} | PV generation power in slot n (kW) | |

TABLE II: ToU Tariff for Germany and Turkey

| Country | Hours | Price/kWh |
|---------|-------------|-----------|
| DE | 08.00-20.00 | 27.52 ct. |
| | 20.00-08.00 | 24.31 ct. |
| TR | 06.00-17.00 | 9.18 ct. |
| | 17.00-22.00 | 14.07 ct. |
| | 22.00-06.00 | 5.71 ct. |

bought energy and earnings from sold energy. Thus, to achieve the optimal result, the objective function must be minimized.

Minimize

$$\sum_{n=1}^N p_n \cdot (P_{G_n}^+ - m \cdot P_{G_n}^-) \cdot T \quad (2)$$

Subject to

$$\sigma_n^+ - \sigma_n^- = P_{PV_n} + P_{B_n}^+ - P_{B_n}^- \quad (3a)$$

$$\sigma_n^+ \leq I_{max} \cdot z_{1,n} \quad (3b)$$

$$\sigma_n^- \leq I_{max} \cdot (1 - z_{1,n}) \quad (3c)$$

$$P_{G_n}^+ - P_{G_n}^- = P_{L_n} - \eta \cdot \sigma_n^+ + \frac{1}{\eta} \cdot \sigma_n^- \quad (3d)$$

$$P_{G_n}^+ \leq (P_{L_n} + \frac{1}{\eta} \cdot I_{max}) \cdot z_{2,n} \quad (4a)$$

$$P_{G_n}^- \leq I_{max} \cdot (1 - z_{2,n}) \quad (4b)$$

$$E_n = E_{n-1} - (P_{B_n}^+ - P_{B_n}^-) \cdot T \quad (5)$$

$$E_n \leq E_{max} \quad (6)$$

$$P_{B_n}^+ \leq B_{max} \cdot z_{3,n} \quad (7a)$$

$$P_{B_n}^- \leq B_{max} \cdot (1 - z_{3,n}) \quad (7b)$$

$$P_{G_n}^+, P_{G_n}^-, P_{B_n}^+, P_{B_n}^-, E_n \geq 0 \quad (8)$$

$$z_{1,n}, z_{2,n}, z_{3,n} \in \{0, 1\} \quad (9)$$

The first constraint of the system is the efficiency effect of the inverter. This effect may change depending on the power flow direction. To represent this nonlinear case, the constraint set given in (3) is used. Binary variable $z_{1,n}$ is used to check power flow direction of the inverter. Moreover, the selling price is calculated by multiplying the actual energy prices by \mathbf{m} . In order to model this effect, the constraint set given in (4), which enables to write the aforementioned cost function, is added. To check the power flow direction between the grid and the load, binary variable $z_{2,n}$ is used. During charge and discharge operations of the battery, E_n continuously changes.

The constraint given in (5) updates the E_n for each time slot. Another important physical limitation for the battery is energy storage capacity which has a constraint as given in (6). Additionally, battery line power limitation is given in (7). Besides, (8) is used to represent nonnegativity of continuous decision variables. Lastly, (9) defines the domain of binary variables $z_{1,n}$, $z_{2,n}$ and $z_{3,n}$.

2) *Optimization Strategies*: Generally, in the existing battery control strategies, control decisions are taken for the considered time instant. However, in this work, depending on how far is planned, two different future planning strategies namely multi time and single time are used to control the power flow of nanogrid for economic concerns.

In multi time strategy, decisions are made for the upcoming day at the beginning of the day using forecast values of the following 96-time slots. In this strategy, decisions are not updated during the day again. Unlike the multi time, by single time strategy, at the beginning of each time slot, forecast values for upcoming 96-time slots are fed into MILP model. However, only the decision for the first time slot is applied to the system. Thereby, in this strategy, decisions are dynamically updated every 15 minutes during the day.

3) *Mismatch Handler*: In real time operation, there is a strategy needed for the cases where forecast and actual generation and consumption values do not match. In this work, it is decided to keep battery line power flow as its forecast value and manage all other power flows accordingly. For example, if generation is higher than expected the excessive power is sold back to the grid instead of charging the battery or if the load is higher than expected the required power is bought from the grid instead of the battery. In this work battery line power flow is kept as forecasted since unlike grid, it has a limitation which could significantly affect the upcoming strategies. To calculate the realized costs the mismatch handler is used along with actual and forecasted values of PV generation and load consumption.

IV. RESULTS

In this section, numerical results of forecasts and optimizations will be shown and different optimization strategies will be compared.

In Fig. 3, mean squared error losses for both load and PV generation throughout the training process can be seen. Although experiments are conducted with 400 epoch, this figure shows only first 50 epoch range, since the rate of change of losses becomes negligible after nearly 50 epochs. When the training process is finished, the resulting mean squared error (MSE) and mean absolute error (MAE) performances are shown in Table III. Furthermore, results of two randomly selected samples from test dataset will be given in Fig. 4.

After optimization, Table IV is constructed in terms of cost values and column labels state as follows:

- *Tariff*: Corresponding country tariff
- *Decision Strategy*: Used optimization strategy
- *System*: Type of the nanogrid system
- *Forecasted Cost*: Cost with forecasted values

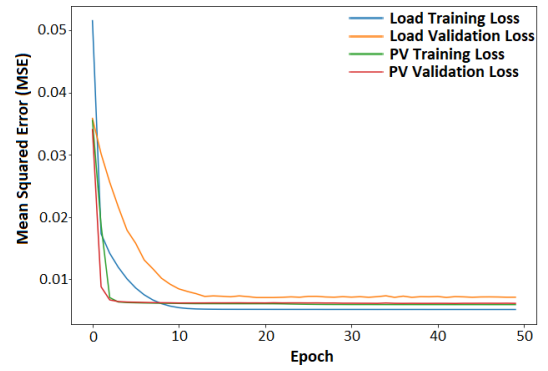

Fig. 3: Training and validation losses for load and PV models

TABLE III: Training and Validation Losses

| Loss | Load Training | Load Validation | PV Training | PV Validation |
|------|---------------|-----------------|-------------|---------------|
| MSE | 5.0877e-3 | 7.1906e-3 | 5.8255e-3 | 6.0386e-3 |
| MAE | 7.1328e-2 | 8.47e-2 | 7.63e-2 | 7.77e-2 |

- *Realized Cost*: Cost with forecasted values in actual case
- *Optimal Cost*: Cost with known actual values
- *Realized Saving*: Saving with forecasted values
- *Saving Rate*: Ratio of the realized saving to the realized cost with the bare system
- *Optimal Saving*: Saving with known actual values
- *Optimality Rate*: Ratio of the realized saving to the optimal saving

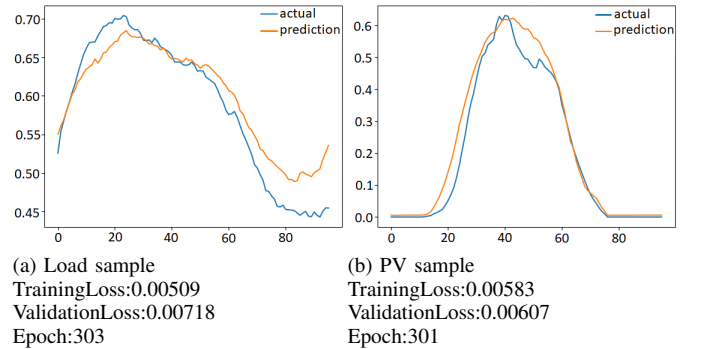

Fig. 4: Validation samples

The results in Table IV show that the electrical demand of a building can be supplied in a more economical way with the use of PV and BSS along with generation and load forecasts. According to the Table IV, the forecasts are giving satisfactory results, which are sufficiently close to the optimal results (over 99% for all cases) calculated by using the actual future data. Another factor emphasized in Table IV is the frequency of the use of optimization algorithm. It can be seen that use of single time strategy is slightly better than the use of multi-time strategy. However, since dynamically calculating strategy for every 15 minutes is more costly in terms of time and processing power, in real time applications multi-time strategy could be more appropriate.

TABLE IV: Optimization Results

| Tariff | Decision Strategy | System | Forecasted Cost | Realized Cost | Optimal Cost | Realized Saving | Saving Rate (%) | Optimal Saving | Optimality Rate (%) |
|--------|-------------------|--------------|-----------------|---------------|--------------|-----------------|-----------------|----------------|---------------------|
| DE | Multi Time | Bare | 912.73 € | 912.73 € | 912.73 € | - | - | - | - |
| DE | Multi Time | Battery-only | 865.25 € | 912.73 € | 912.73 € | 0.00 € | 0.00% | 0.00 € | - |
| DE | Multi Time | PV+Battery | 241.42 € | 297.83 € | 294.48 € | 614.90 € | 67.37% | 618.25 € | 99.46% |
| DE | Single Time | Bare | 912.73 € | 912.73 € | 912.73 € | - | - | - | - |
| DE | Single Time | Battery-only | 868.71 € | 912.73 € | 912.73 € | 0.00 € | 0.00% | 0.00 € | - |
| DE | Single Time | PV+Battery | 243.84 € | 297.08 € | 294.48 € | 615.65 € | 67.45% | 618.25 € | 99.58% |
| TR | Multi Time | Bare | 324.88 € | 324.88 € | 324.88 € | - | - | - | - |
| TR | Multi Time | Battery-only | 186.83 € | 205.60 € | 204.77 € | 119.27 € | 36.71% | 120.10 € | 99.31% |
| TR | Multi Time | PV+Battery | -31.57 € | -8.59 € | -10.10 € | 333.47 € | 102.65% | 334.98 € | 99.55% |
| TR | Single Time | Bare | 324.88 € | 324.88 € | 324.88 € | - | - | - | - |
| TR | Single Time | Battery-only | 188.38 € | 205.74 € | 204.77 € | 119.14 € | 36.67% | 120.10 € | 99.20% |
| TR | Single Time | PV+Battery | -30.23 € | -8.78 € | -10.10 € | 333.66 € | 102.70% | 334.98 € | 99.61% |

V. CONCLUSION

The proposed method may provide 99.5% optimality rate, thanks to the forecasted load and PV generation. This conclusion reveals that, usage of BSS with PV unit provides benefits for both consumers and the grid. Once the numerical results are considered in detail, it can be seen that in Turkey it is more possible to benefit from BSS as there are more time periods in ToU tariff and there exists a high variation among the related prices compared to Germany. On the other hand, for Germany sole usage of BSS may be useless since ToU tariff prices for different time slots are much closer. Germany may use BSS with PV units at the nanogrid systems to increase the economic savings. As a result, utilization of PV with BSS in both Turkey and Germany increases customer benefits.

In order to add the socio-economic factors in the load forecast, as a future work, national and religious holidays will be added to the load forecast model, as those determine power consumption amount and location. A long period having sinusoids or decision tree approach can be added as a pre-stage to load forecasting, and LSTM models can be created for different cases. In addition, weekends and weekdays can be modeled separately or such a structure that detect and learn periodicities of different behaviors will also be added. Moreover, the load forecast method will be carried to household base, which will result in an intermittent load characteristic, rather than a smooth curve. This situation will result in use of probabilistic models because of the uncertain intermittenencies. Finally, effect of weather can be added to load forecast [13].

PV generation depends environmental conditions. Therefore, to enhance the proposed method, we will added weather forecast into the PV generation forecast part. As in [14], in which artificial neural network (ANN) model is used for grid-connected MW range PV systems, the historical beam solar irradiance and weather data can be integrated to PV forecast.

Finally the optimization problem can be improved to control bus voltage, as high voltage magnitude disables PV operation due to the tripping of the inverter system.

REFERENCES

[1] Entso-E, "Yearly Statistics & Adequacy Retrospect 2015," Entso-E, Brussels, Tech. Rep., 2017. [Online]. Available: www.entsoe.eu

[2] H. Farhangi, "The path of the smart grid," *IEEE Power and Energy Magazine*, vol. 8, no. 1, pp. 18–28, 2010.

[3] M. Rafiee Sandgani and S. Siropour, "Energy Management in a Network of Grid-Connected Microgrids/Nanogrids Using Compromise Programming," *IEEE Transactions on Smart Grid*, vol. 3053, no. c, pp. 1–1, 2016.

[4] N. Liu, X. Yu, W. Fan, C. Hu, T. Rui, Q. Chen, and Z. Jianhua, "Online Energy Sharing for Nanogrid Clusters: A Lyapunov Optimization Approach," *IEEE Transactions on Smart Grid*, vol. 14, no. July, pp. 1–1, 2017. [Online]. Available: <http://ieeexplore.ieee.org/document/7845698/>

[5] A. Fentis, L. Bahatti, M. Mestari, M. Tabaa, A. Jarrou, and B. Chouri, "Short-term PV power forecasting using Support Vector Regression and local monitoring data," in *2016 International Renewable and Sustainable Energy Conference (IRSEC)*. IEEE, 11 2016, pp. 1092–1097.

[6] A. Alfadda, R. Adhikari, M. Kuzlu, and S. Rahman, "Hour-ahead solar PV power forecasting using SVR based approach," in *2017 IEEE Power & Energy Society Innovative Smart Grid Technologies Conference (ISGT)*. IEEE, 4 2017, pp. 1–5. [Online]. Available: <http://ieeexplore.ieee.org/document/8086020/>

[7] A. Ahmad, N. Javaid, M. Guizani, N. Alrajeh, and Z. A. Khan, "An Accurate and Fast Converging Short-Term Load Forecasting Model for Industrial Applications in a Smart Grid," *IEEE Transactions on Industrial Informatics*, vol. 13, no. 5, pp. 2587–2596, 10 2017. [Online]. Available: <http://ieeexplore.ieee.org/document/7779053/>

[8] M. Yang, W. Li, H. Zhang, and H. Wang, "Parameters Optimization Improvement of SVM on Load Forecasting," in *2016 8th International Conference on Intelligent Human-Machine Systems and Cybernetics (IHMSC)*. IEEE, 8 2016, pp. 257–260. [Online]. Available: <http://ieeexplore.ieee.org/document/7783832/>

[9] M. Kazemi and H. Zareipour, "Long-term Scheduling of Battery Storage Systems in Energy and Regulation Markets Considering Batteries lifespan," *IEEE Transactions on Smart Grid*, vol. 3053, no. c, pp. 1–1, 2017. [Online]. Available: <http://ieeexplore.ieee.org/document/7972903/>

[10] Q. Wei, G. Shi, R. Song, and Y. Liu, "Adaptive Dynamic Programming-Based Optimal Control Scheme for Energy Storage Systems with Solar Renewable Energy," *IEEE Transactions on Industrial Electronics*, vol. 64, no. 7, pp. 5468–5478, 2017.

[11] E. L. Ratnam, S. R. Weller, and C. M. Kellett, "An optimization-based approach for assessing the benefits of residential battery storage in conjunction with solar PV," *Proceedings of IREP Symposium: Bulk Power System Dynamics and Control - IX Optimization, Security and Control of the Emerging Power Grid, IREP 2013*, vol. 2, pp. 1–8, 2013.

[12] T. Y. Lee, "Operating schedule of battery energy storage system in a time-of-use rate industrial user with wind turbine generators: A multi-pass iteration particle swarm optimization approach," *IEEE Transactions on Energy Conversion*, vol. 22, no. 3, pp. 774–782, 2007.

[13] V. Dehalwar, A. Kalam, M. L. Kolhe, and A. Zayegh, "Electricity load forecasting for Urban area using weather forecast information," in *2016 IEEE International Conference on Power and Renewable Energy (ICPRE)*. IEEE, 10 2016, pp. 355–359. [Online]. Available: <http://ieeexplore.ieee.org/document/7871231/>

[14] A. K. Sahoo and S. K. Sahoo, "Energy forecasting for grid connected MW range solar PV system," in *2016 7th India International Conference on Power Electronics (IICPE)*. IEEE, 11 2016, pp. 1–6. [Online]. Available: <http://ieeexplore.ieee.org/document/8079388/>